

# USCG

## OCS Inspection & Certification

- Lieutenant Mike Franklin
- USCG MSD Kenai
- 907-283-3292
- Michael.R.Franklin@USCG.MIL



Homeland  
Security



# Why should we always try and do the right thing?

- Because the boss said so and the boss is always right!
- It will pay off in the long run!
- There may be a bonus or promotion in it for me!
- Or could it be.....



Homeland  
Security



# Nobody likes a bad day especially offshore!



Homeland  
Security



# Examples

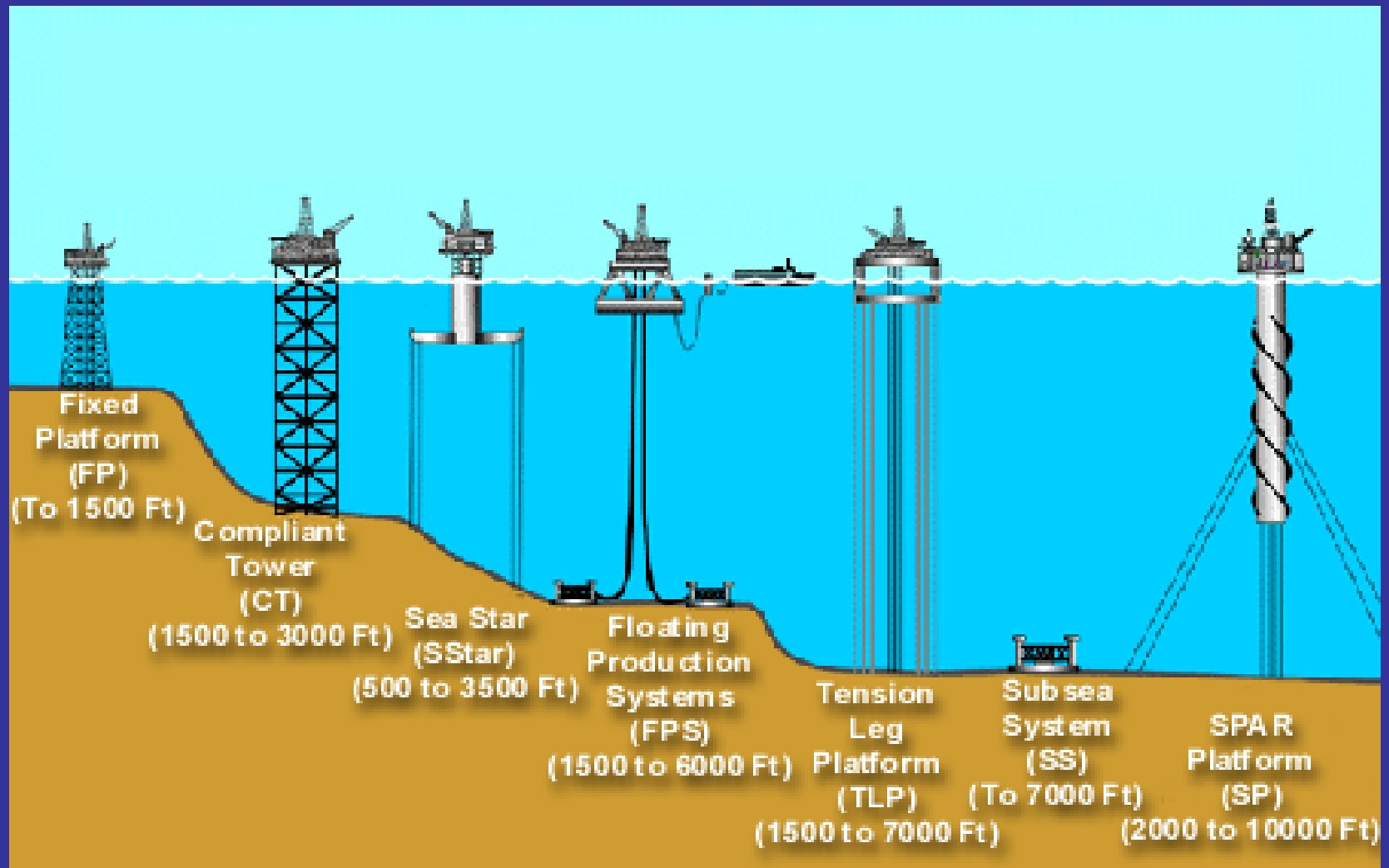

# What are we talking about here?

## Fixed Platforms



Homeland  
Security



# “Jack Ups”



Homeland  
Security



# Tension Leg Platform (TLP)

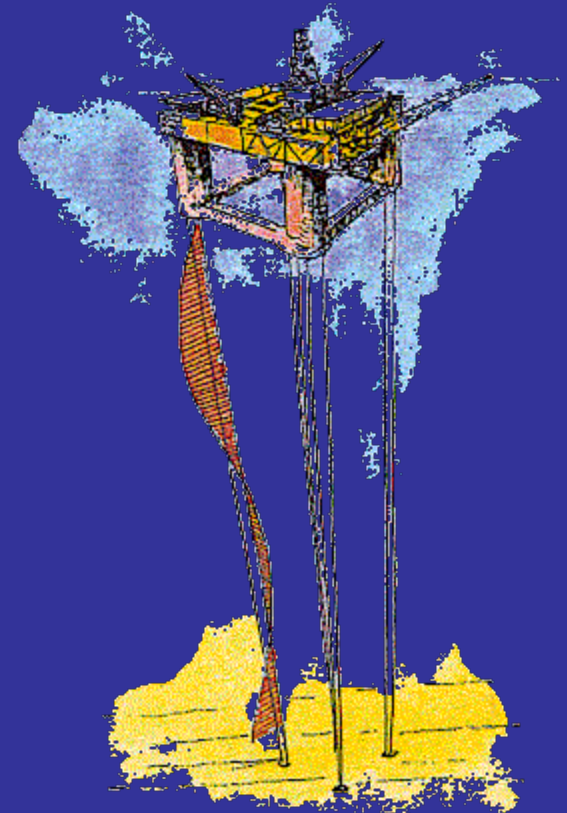
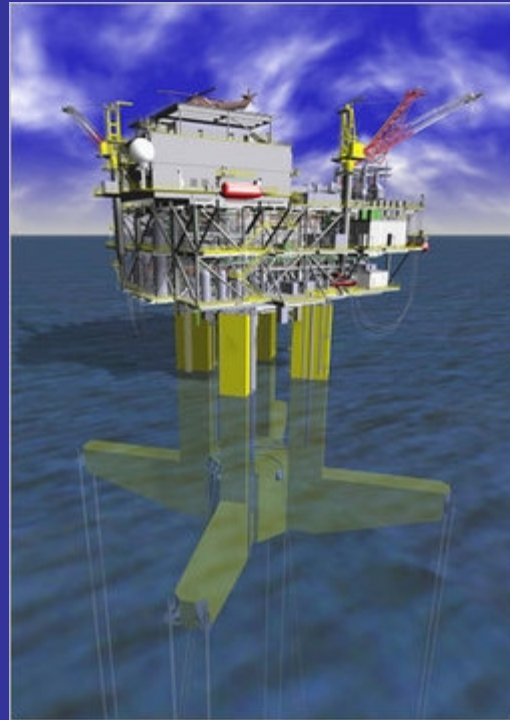
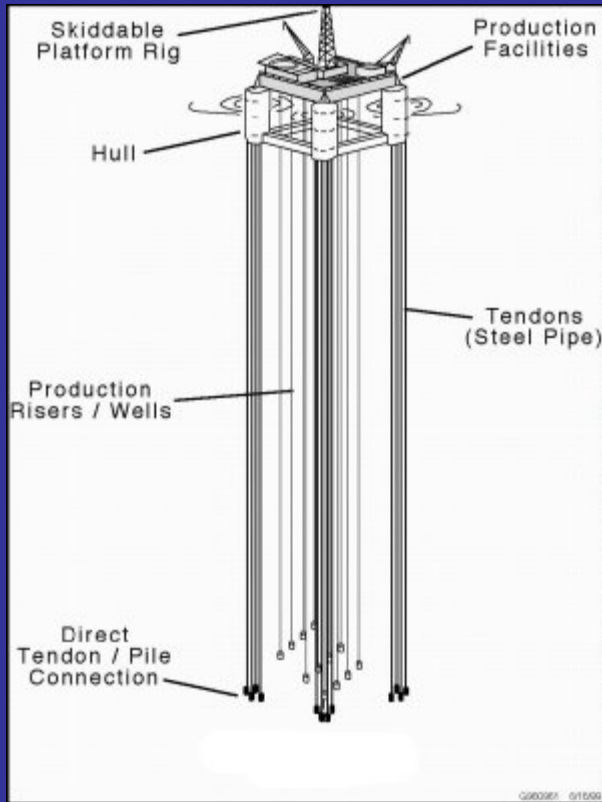

Homeland  
Security



# Spar Floating Offshore Installation

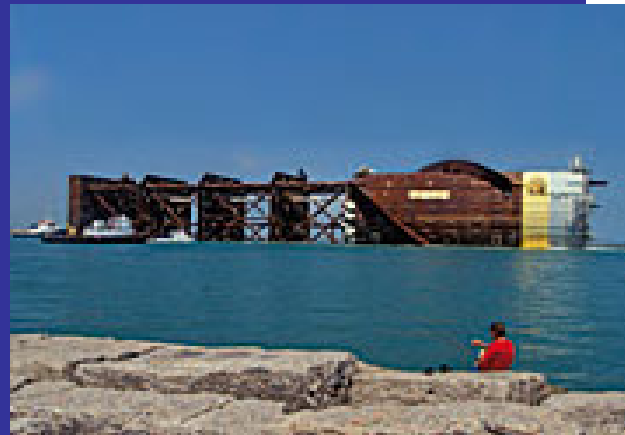
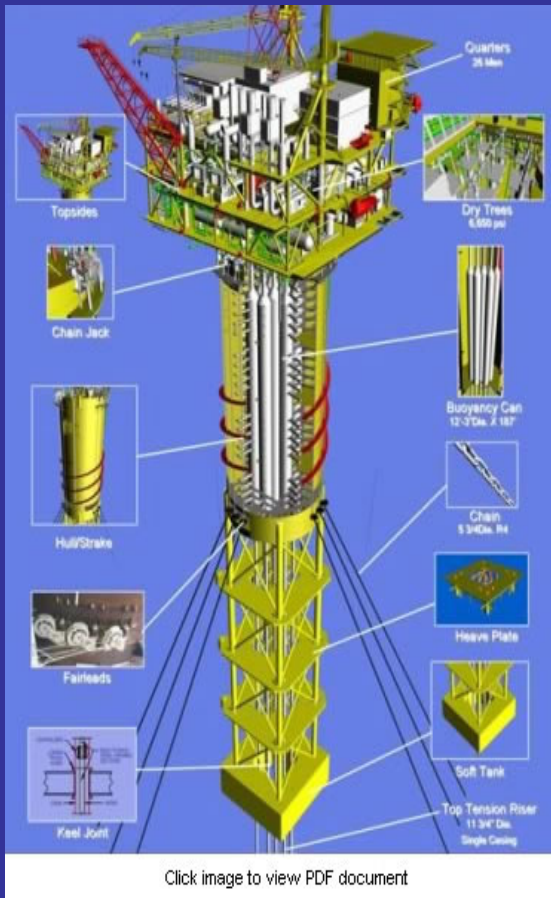

Homeland  
Security



# Semi Submersible



Homeland  
Security



# Drill Ships



Homeland  
Security



# References and Guidance (Basic) Mobile Offshore Drilling Units (MODUs)

- 46 CFR Part 107-109 (Subchapter I-A)
- Numerous Pubs – CFRs, NVICs, Policy ltrs, Tech notes, MOUs, MSM & others
- Drilling Rigs
- Jack Ups
- Semi-Submersibles
- Drill Ships



Homeland  
Security



# Floating/Fixed Offshore Installations

- 33 CFR part 140-147 (Subchapter N & 46 CFR Subchapter I-A).
- Tension Leg Platforms (TLP).
- Mini TLPs.
- Spars.
- Fixed Platforms MOUs with MMS.
- You just have to love the acronyms.....



Homeland  
Security



# New Construction Plan Review & USCG Marine Inspector Oversight

- Done by USCG Marine Safety Center.
- Built to approved plans, work may start prior to approval at risk of change.
- MI oversight ensures all required tests of welding, vital systems, fire fighting, life saving, pollution, manning, machinery, propulsion, navigation & drill package.



Homeland  
Security



# Certification - US Flag MODU

- USCG Certificate of Inspection (COI) issued after all deficiencies (CG 835s) cleared during construction and initial inspection.
- Temporary COI issued valid for 1 Year.
- Original COI issued after & valid for 5 years with annual inspections.



Homeland  
Security



# Special Exam in Lieu of Dry-dock MODUs only 46 CFR 107

- Due twice in five (years) not to exceed 3.
- Completed in phases, phase 1 hull and ISE phase 2 leg to spud can high stress connections NDT.
- Require Marine Chemist Cert, enter all spaces, inspect jacking houses, and all structural members.



Homeland  
Security



# Dry Dock continued Fixed Offshore Installations (FOIs)

- In - Service Inspection Plan (ISIP) FOI
- Why is this?
- Well it is awful hard to get these units into shipyard dry-dock!
- ISIP plan approved by MSC.
- Enter 40% of the hull each year of a five year cycle for credit. Result is 2 in 5.



Homeland  
Security



# Foreign Flag Certification Regulations and Certification

- 79-89 IMO MODU Codes.
- Panama/Marshall Island Regs.
- Navigation and Vessel Inspection Circular (NVIC) 3-88 change 1 Issuing of Certificate of Compliance (COC).
- No MSC plan review, new construction/modification oversight or Hull/Dry dock/ISE. This done by Class/Flag State.



Homeland  
Security



# Certificate of Compliance (COC)

- Issued for 2 year period.
- Issued to foreign flagged MODU working in US waters after compliance exam.
- Compliance exam similar to COI annual inspection.



Homeland  
Security



It is always a good idea to use  
USCG approved lifesaving &  
firefighting safety equipment



Homeland  
Security



# “The Top Ten List” of CG 835s based on input from USCG in GOM 2003.

- #10 - Bilge Systems.
- No or low suction, missing labels on manifold.
- Clogged sumps and piping stuck valves.
- #9 - Temp/Pressure Alarms & Shutdowns.
- Mechanics unaware of need to test component vs test system, no means to test.



Homeland  
Security



# The Top Ten List (contd)

- #8 - 3rd Party “Temporary” Installations.
- Sloppy Installs, improper equipment for location. Portable Quarters issues.
- Dead end wires left behind and plastic wire ties used everywhere.
- #7 – Testing of E-gens.
- Weekly, monthly load test, log and record.



Homeland  
Security



# Top Ten List (contd)

- #6 – Cranes
- Annual exam past due, 5 year proof load test overdue, poor condition of cabs.
- #5 – Fixed Fire Suppression Systems
- Instructions for activation not legible, Annual servicing left to 3<sup>rd</sup> party not IAW 46 CFR 107, crew unfamiliar with location.



Homeland  
Security



# Top Ten List (contd)

- #4 – 46 CFR 109 Drills & Training
- Training materials and records don't meet new 109 post 1996, drills don't contain required key components.
- #3 – Mud Pit Rooms.
- Bulkheads and overheads not maintained gas tight, doors propped open, non sealing.



Homeland  
Security



# Top Ten List (contd)

- #2 – Purged equipment in Hazardous locations.
- No alarms on loss of purge.
- No equipment shut down on loss of purge.
- Any guesses as to what #1 is??????????????



Homeland  
Security



# Top Ten List Continued

- **#1 – Primary Lifesaving**  
(i.e. Lifeboats & Life Rafts)
- Inventories not up to date, boat not launched per required frequency.
- Breathing air bottles empty or low, sprinklers don't work.
- Limit switches adjusted incorrectly.
- Poor overall condition, improper stowage height for life rafts.



Homeland  
Security



# Some things to remember.

The USCG is an extra set of eyes and will notice the items (industry) may walk by each day.

- Safety of the vessel, crews, industry and the environment are our main focuses.
- If you have questions please ask any time.
- Relax we are here to help!



Homeland  
Security



# Time To Go!!!!



**Well Pilgrim, You're Burning Daylight!**



Homeland  
Security



# THANK YOU FOR YOUR TIME!

LT Michael Franklin

USCG MSD Kenai Alaska

907-283-3292

Michael.R.Franklin@USCG.Mil

Helpful Links –

<http://www.uscg.mil/nmc>

<http://homeport.uscg.mil>



Homeland  
Security

